



PRODUCT
INFORMATION
SHEET

Memco Elite

Model 662

INFRA RED SAFETY CURTAIN FOR LIFTS

- Robust 13.5mm wide profile - for increased rigidity
- Easy to install
- 154 criss-cross beams offer protection up to a height of 1.8m
- Diagonal beams-to-close
- Low power consumption
- Microcontroller based TX and RX (optional power supply box)
- NPN and PNP output versions available
- Diagnostic LEDs and timeout software
- 4m range

INTRODUCTION

The Memco élite 662 infra-red detector system is designed for new and existing installations where the detectors are fitted on car-mounted brackets. The assembly is extremely rigid because of the increased strength offered by the 13.5mm profile. Couple with this, a more versatile installation bracket allows simple, varied height adjustments when fitting.

In this "static installation" a criss-cross curtain of 154 infra-red beams is generated (see Fig 1). The detector cables are not subjected to movement and the detectors are protected from vandalism.

The detectors can also be mounted on the car doors and will adjust automatically to optimise detection performance. When the doors open the beam pattern changes from

92 beams to 154 beams at typically 650mm. When the door separation is below 250mm then the beam pattern reduces to 72 beams.

Surface mount technology has led to great improvements in optics, allowing diagonal beams to function to door close. The special filter lens, unique to Memco, used in conjunction with the surface mount transmit and receive diodes, to optimise the performance.

Improved circuit protection has been added which guards against common wiring errors during installation. Lower power consumption using a switched mode power supply makes teh edges compatible with modern elevator control systems.

Surface mount diodes are manufactured by a technique which improves both consistency and reliability of the diodes, therefore improving overall quality.

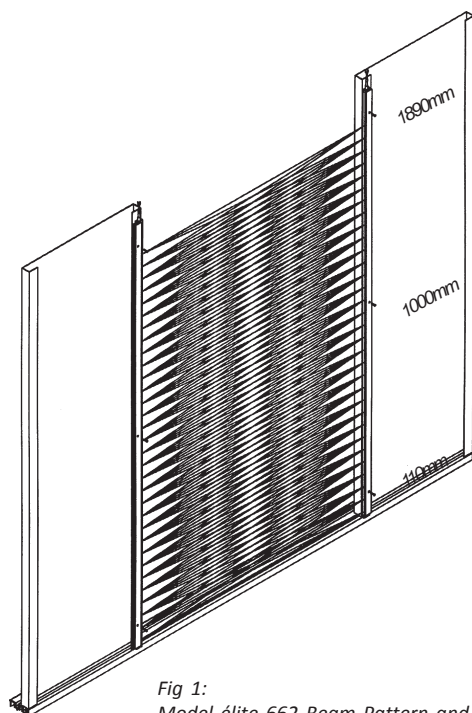

Fig 1:
Model élite 662 Beam Pattern and Fixing Screws

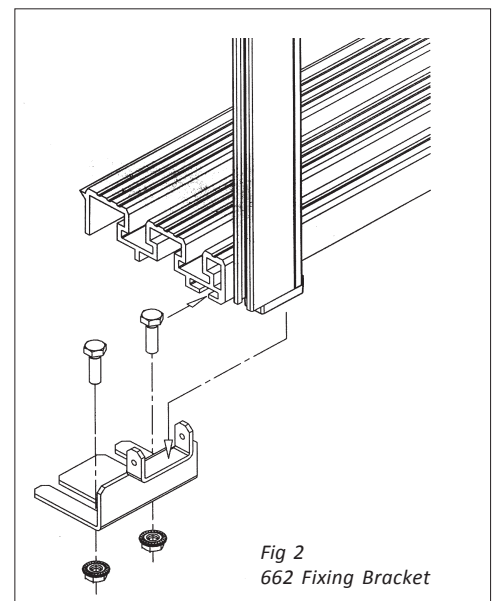

Fig 2
662 Fixing Bracket

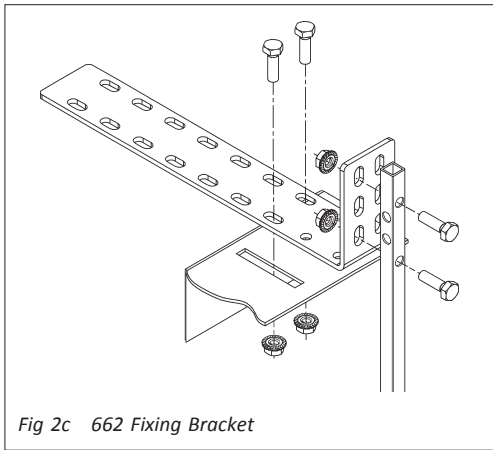
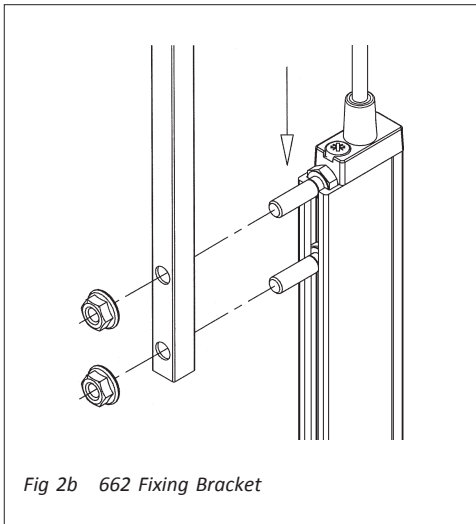

Fig 2c 662 Fixing Bracket

The detectors are simple to install either dynamically or statically. Figs 2a, 2b and 2c show the brackets used for static installation, which are available from Memco (ref. 662 800-011). Dynamic installation is by three No 6 self-tapping screws as shown in Fig 1. The detectors are wired directly to the door operator/lift controller, as shown in Fig 3.

The dense beam pattern will pick up even small objects between the doors and any interruption to the infra-red beams across the door-opening causes the NPN or PNP output to switch state. No setting-up is required. Both detectors are supplied with a highly flexible cable, 4.0m long. Each cable core is terminated using boot lace ferrules. They are connected to the door operator/lift controller as shown in Fig 3.

Each detector is housed in a robust 13.5mm profile (see Fig 4). Both detectors use an internal microcontroller and are manufactured using surface mount devices (SMD). The TX has two diagnostics LEDs that are visible through the lens and provide an indication of a trigger and a possible RX or TX fault. The RX has been designed to provide a high level of light immunity.

▪ **System Connection**

The system has been designed to connect directly to the door operator or lift controller (Fig 3). When the infra-red beams are obstructed, a system trigger occurs and switches a transistor output. This is used by the door/lift controller to re-open the doors.

The standard transistor output is PNP Normally-Closed (PNP-N/C). Other transistor configurations (PNP-N/O, NPN-N/C, NPN-N/O) are available on request but PNP-N/C is recommended because it offers fail-safe operation.

The transistor may be used to drive a load such as a relay coil or an opto-isolated input on the lift controller. A PNP configuration means the load should be connected between the output and 0V (i.e. when the transistor is turned on the load will draw current from the transistor output). A Normally-Closed (N/C) configuration means the transistor is turned on when the light curtain is unobstructed.

If it is not possible to use the system transistor output, or a regulated DC supply is unavailable, then a Model 280 or 281 Power Supply unit can be used. See Fig 5.

▪ **System Software**

The microcontroller to control the Model élite 662 is positioned in the top part of the TX and RX detector assembly. In addition to generating the infra-red beam pattern and detecting obstructions, the system has additional software features, as follows.

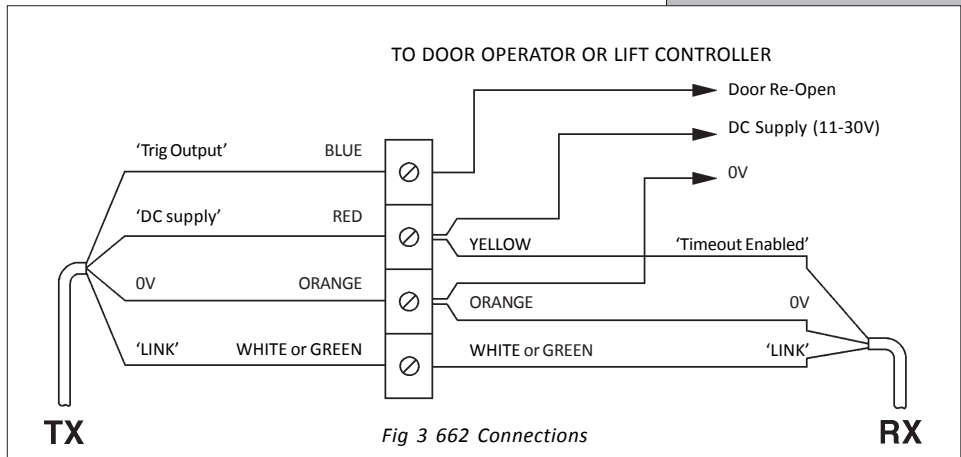
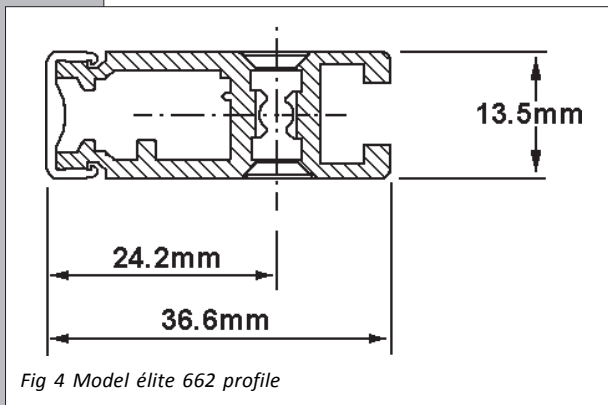

Fig 3 662 Connections



▪ **Power Reduction Software**

This patented software feature is designed to put the system into a less active state when the lift is not in use and prolong the life span of the detectors. When the detectors stop very close to each other, the Power Reduction mode is operated after a delay of 10 secs. In this mode the scan speed is reduced to once every 2 secs. If the doors start to open, or an obstruction is detected, then the normal scanning and trigger mode is resumed. The Power Reduction software will not function if the detectors are fitted in a static position.

▪ **Timeout Function**

If the timeout option is selected during installation, then this software feature will allow up to 5 non-adjacent infra-red TX diodes to be ignored, if they are permanently obstructed. There is a delay of 10 secs before the trigger is ignored and the beam scanning is resumed. This is a useful service feature which enables TX diodes damaged by vandalism to be ignored while arrangements are made to replace the unit.

• **Power Supply Unit - AC Supply**

The Model 280 Power Supply should be used if only an AC supply voltage is available or if the door operator/lift controller cannot accept a transistor output. It provides a regulated DC supply for the detectors and a relay output for connection to the door re-open circuit.

The Model 280 Power Supply is factory-set to work with the standard Model 662 transistor configuration (PNP-N/C) for fail safe operation. However, it can easily be changed to work with other Model 662 transistor configurations (PNP-N/O, NPN N/C or NPN-N/O) using two simple switches.

The unit is also fitted with a beeper and beeper on/off switch.

• **Power Supply Unit - DC Supply**

The Model 281 Power Supply should be used only if an unregulated DC supply voltage (15V to 36V) is available, or if the door operator/lift controller cannot accept a transistor output. It provides a regulated DC supply for the detectors and a relay output for connection to the door re-open circuit.

The Model 281 Power Supply is factory-set to work with the standard Model 662 transistor configuration (PNP/N/C) for fail safe operation. However, it can easily be changed to work with other Model 662 transistor configurations (PNP-N/O, NPN-N/C or NPN-N/O) using two simple switches.

The unit is also fitted with a beeper on/off switch.

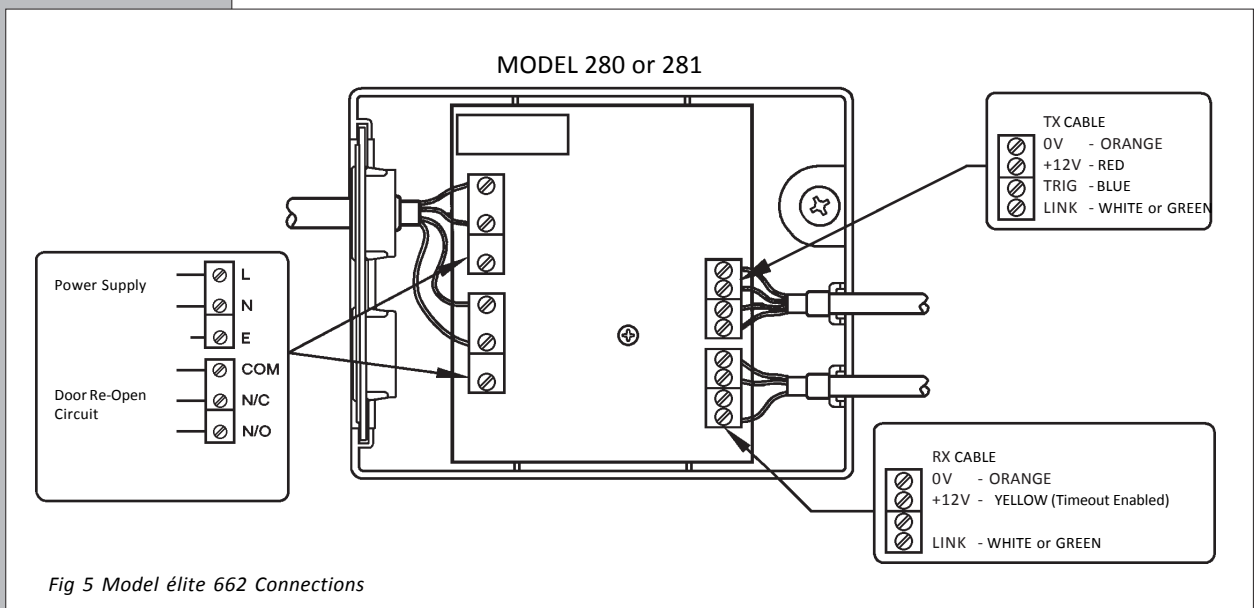

▪ **Trouble-Shooting LEDs**

The two red trouble-shooting LEDs are located in the TX detector and are positioned at 25cm and 31cm from the top of the detector. The various LED states are tabulated below with the associated causes;

LED	Status	Possible Cause
<input type="checkbox"/> <input type="checkbox"/>	OFF OFF	No Power
<input checked="" type="checkbox"/> <input type="checkbox"/>	FLASHING OFF	TX/RX connection open circuit
<input checked="" type="checkbox"/> <input type="checkbox"/>	ON OFF	Triggered state obstruction between detectors
<input checked="" type="checkbox"/> <input checked="" type="checkbox"/>	ON ON	Normal scanning state
<input checked="" type="checkbox"/> <input checked="" type="checkbox"/>	ON FLASHING	A diode has been timed out

SPECIFICATIONS - Model élite 662	
Detector size	13.5mm (17/32") x 36.6mm (17/16 ") x 2000mm (6ft 6¾")
Detector Cable	4.0m on both TX and RX terminated with boot lace ferrules
Fixing Kit	10 x 6mm P-Clip 10 x No 8 x 12mm S/T Screws 6 x No 6 x 20mm S/T CSK Head Screws
Distance between bottom beam & bottom of housing	23mm
Distance between top beam & bottom of housing	1836mm
Range	4m
Number of diodes per detector	32
Distance between diodes	58.5mm
Number of beams	154 when detectors are typically more than 650mm apart 94 when detectors are typically less than 600mm apart 72 when detectors are typically less than 250mm
Input Voltage	11-30V DC max @ 80mA max (excluding PNP load current). Supply must have a ripple voltage of no more than 36V peak
Output	NPN or PNP (factory set)
Indicators	2 red LEDs on TX (visible through the lens)
Light immunity	>100,000 lux
Operating temperature range	0°C to 65°C as per BS2011 Part2.1 Ab and Part2.2 Bb
Temperature storage	-20°C & +80°C for 24 hours at each temperature
High temperature/high humidity	BS2011:Part2.1Db:1981, Variant2 at +55°C
EMC compliance	Emissions to EN12015, Immunity to EN12016
IP rating	IP54 in accordance with BS EN60529:1992
Sleep Software Patent Nos	UK 9822359.7 Germany 29918009.3 Japan 291527/1999 USA 09/416,585

ORDERING INFORMATION	
Part No.	Description
662 080	Set of Model 662 Detectors each with 4.0m cable and NPN-N/C output
662 090	Set of Model 662 Detectors each with 4.0m cable and NPN-N/O output
662 180	Set of Model 662 Detectors each with 4.0m cable and PNP-N/C output
662 190	Set of Model 662 Detectors each with 4.0m cable and PNP-N/O output
280 000	115/230V AC power supply
281 000	15V - 36V DC power supply
662 800-011	Static Fixing Kit

This product is designed for use in elevators with powered automatic doors where the closing force is 25N/mm or less as per EN81 requirements. It should be installed by qualified personnel only, therefore any use outside of this application is at the installer's own risk and should be assessed appropriately.

As a result of our policy of continual improvement, the information in this document is subject to change without notice and it is intended only as general guidance on product performance and suitability. This information shall not form part of any contract.

A HALMA COMPANY



MEMCO LTD, CLYDE HOUSE
REFORM ROAD, MAIDENHEAD
BERKS SL6 8BY, UK
TELEPHONE: +44 1628 770734
FACSIMILE: +44 1628 621947
www.memco.co.uk