



PRODUCT
INFORMATION
SHEET

Memco Pana40Plus3D

FOR SAFETY AT ALL LEVELS

- “3D” zone to give extended protection into the landing
- 40 parallel or 194 criss-cross beams offer protection up to a height of 1.8m
- Selectable modes of 3D operation to suit various installation sites
- Advanced 3D diagnostic self-check
- Standard and Slimline profiles available
- Greatly reduces the chances of passenger injury by the landing door
- Damage to landing doors from trolleys and hospital beds is essentially eliminated
- No increase in installation time compared with conventional infra-red detection systems
- Patented 3D and Power Reduction Features

The Pana40 Plus-3D safety system has two independent detection systems (see Fig 1)

- Light Curtain – infra-red beams operating directly between the doors.
- “3D” Detection – infra-red proximity detection operating in the landing zone.

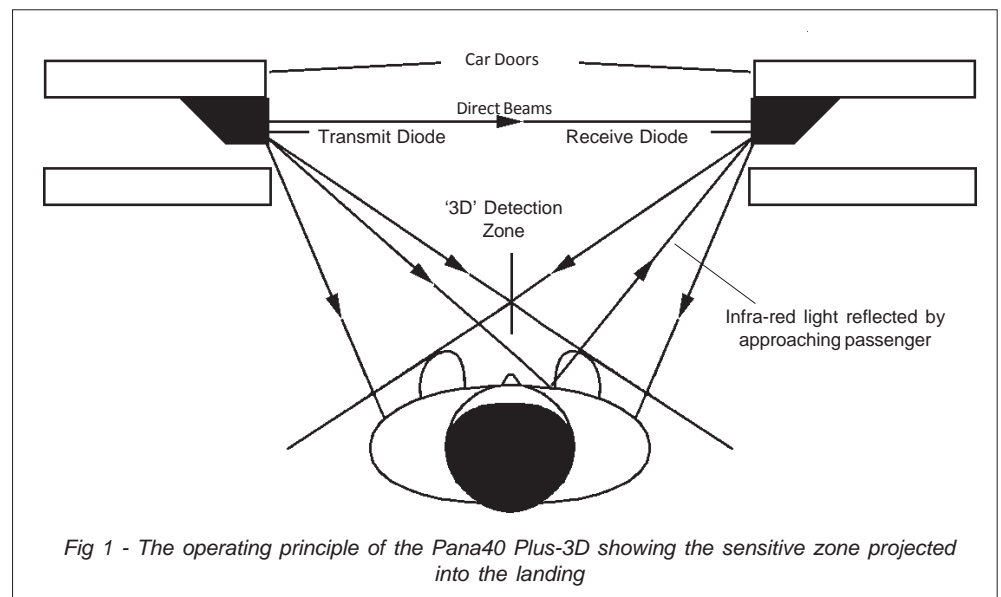

Fig 1 - The operating principle of the Pana40 Plus-3D showing the sensitive zone projected into the landing

Any object causing interruption of the direct beams or reflections within the 3D detection zone will trigger the system and re-open the lift doors.

The Light Curtain beams operate at heights from 25mm to 1800mm above floor level. The 3D Detection Zone covers from just above floor level to 1550mm. The 3D detection range is equal to approximately half the door separation. As the doors close the 3D detection zone moves inwards giving increasingly sensitive protection to the door aperture.

The system can be configured for different operating modes to suit particular installation

needs. For example the “3D Timeout” mode is ideal for hospitals because the doors will only start to close if the 3D detection zone is clear.

The Pana40 Plus-3D detectors are manufactured in various profiles to suit a wide variety of doors – including both centre-opening and side-opening doors. (See Fig 2 to Fig 6).

The detectors can be used with all 3D versions of the Pana40 Plus controller. These are available in 40 or 194 beam pattern versions and for various supply voltages (AC or DC). See the ordering table for details.

DETECTOR PROFILES (770 Series)

There are three different Pana40 Plus-3D detector profiles – Standard, Slimline and Ultraslim. These come with appropriate fixing kits to fit the detectors in one of five types of installation. Please specify the required installation type using the Part Numbers shown.

Standard: Part No 770 000

The Standard detectors are designed to fit on the side of the door flush with the door edge. They are fixed using self-tapping screws, through height-adjustable brackets and covered by a vandal-resistant finger guard (see Fig 2). These detectors are particularly suitable for centre-opening doors with a wide running clearance where the detector also doubles as a sightguard. The cable can be routed from the top of the detector and secured with the P-clips provided.

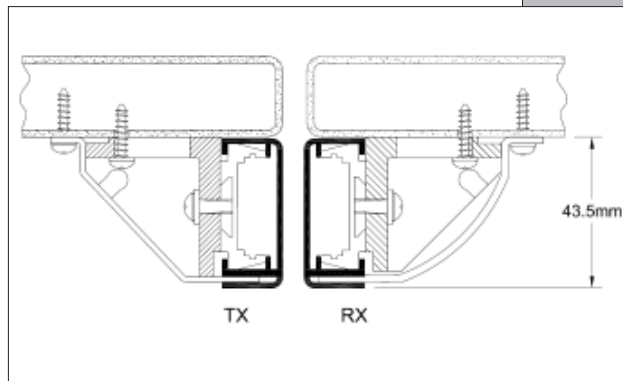

Fig 2

Leading Edge: Part No 770 010

The Leading Edge detectors are designed to fit on the leading edge of the door or on the slampost. These detectors are particularly suitable for side-opening doors, but can be used on centre-opening doors. The door or slampost is drilled in four places and the detectors fitted by means of cap titive bolts, sliding in a track on the back of the detectors. Alternatively the detectors may be secured through the detector housing on the door edge, using the screws provided (see Fig 3). Fixings for both methods are included in the fixing kit.

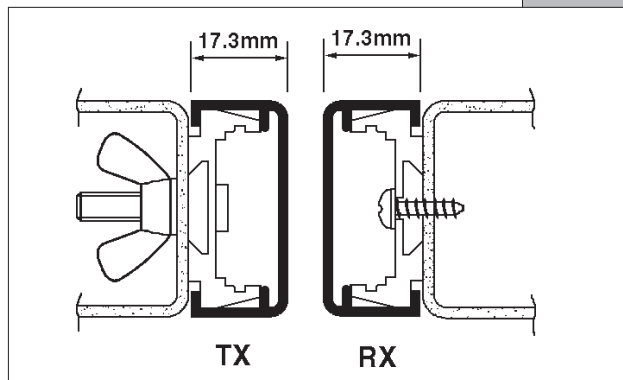

Fig 3

Mixed Set (Standard and Leading Edge): Part No. 770 020

The Mixed Set is convenient for side-opening doors where it is desirable to have a Standard TX detector on the door and a Leading Edge RX detector on the slampost (see Fig 4). If the door opens in the opposite direction it will be necessary to swap the plastic lenses so that the TX is kept on the left-hand side.

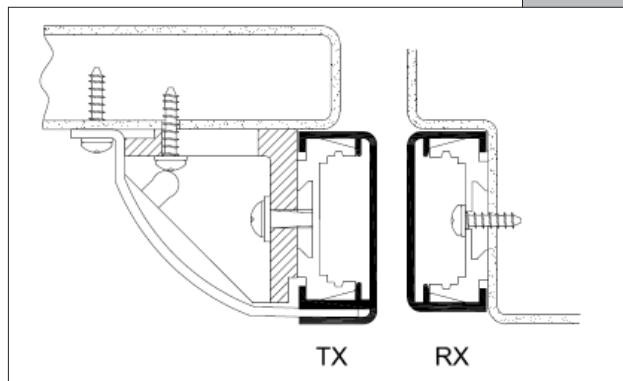

Fig 4

Slimline: Part No. 771 000

The Slimline detectors are only 15.5mm wide and designed to fit on the side of close-coupled doors. The detectors are mounted to the side of the car doors using the self-tapping screws provided in the fixing kit. Optional PVC finger guards (Part Nos. 007 137 and 007 138) are available to fill the 30mm gap found on some door types (see Fig 5).

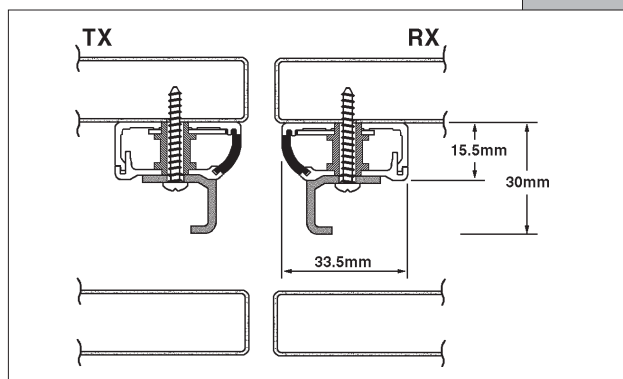

Fig 5

Ultraslim: Part No 774 000

The Ultraslim detectors are only 9.8mm wide which allows them to be fitted to virtually all lifts. They are particularly suited to lifts with narrow running clearances. The detectors are mounted to the side of the car doors using self-tapping screws provided in the fixing kit (see Fig 6).

CONTROLLERS (840 Series 3D)

The Pana40 Plus-3D Controllers operate the Pana40-Plus 3D detectors. They are housed in a black steel box which is extremely durable and normally fitted on top of the lift car using self-tapping screws. The controllers are available in several versions. Please see the ordering table for version details.

Model 840/841/843 3D Controllers

All controllers have the following standard features.

- **Power Reduction Software**

This patented software feature is designed to put the system into a less active state when the lift is not in use and prolong the life span of the detectors. When the detectors stop very close to each other, the Power Reduction mode is operated after a delay of 10 secs. In this mode the scan speed is reduced to once every 2 secs. If the doors start to open, or an obstruction is detected, then the normal scanning and trigger mode is resumed. The Power Reduction software will not function if the detectors are fitted in a static position.

- **'Trigger' Tone**

An audible 'Trigger' tone will inform users they are preventing the doors closing. A 'Tone' switch is available to disable this feature.

- **Test Diagnostics**

Special test diagnostics allows the installer to quickly check for system faults. Simply turn the 'Mode' switch to 'Test' and the system will report any faults on a diagnostics display (e.g. 'cable disconnected').

- **Light Curtain Timeout**

Setting the 'Timeout' switch on will allow a partially damaged detector to continue working safely until it can be replaced. It does this by ignoring a permanent trigger on up to 5 non-adjacent beams (e.g. due to vandalism). The timeout period is adjustable from 10 seconds to 70 seconds. On 194-beam controllers only 4 non-adjacent beams are allowed to timeout.

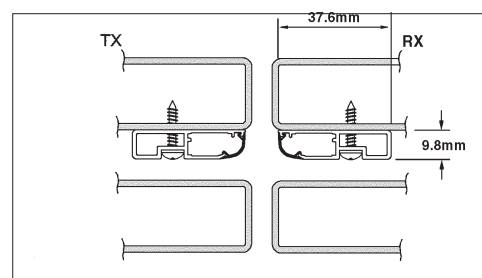

Fig 6

- **3D Self Test**

When the doors are closed the controller performs a test of the 3D system sensitivity. This ensures safe and reliable 3D operation. The installer can set a jumper to select whether a 3D self-test failure should open the doors or simply be reported on the diagnostics screen.

- **3D Configuration Switches**

The controllers are fitted with a small plug-in board with 4 DIP switches. Switches 1 and 2 set the 3D Operating Mode while switches 3 and 4 set the 3D sensitivity.

- **'3D Timeout – 20 seconds'** – In this mode the 3D detection is activated when the doors have reached their fully opened position. The system will allow a continuous 3D trigger to hold the door open for 20 seconds. If the 20 second timer expires then the doors are allowed to close with a warning beep. (This beep will occur regardless of the 'Tone' switch position.) If the 3D zone becomes clear before the 20 second timer expires then the timer is reset and the doors are allowed to close. If the light curtain is broken then the timer is reset and the doors re-opened.

- **'3D Timeout – 10 seconds'** – This mode is identical to '3D Timeout – 20 seconds' except that the 3D timeout period is now fixed at 10 seconds.

- **'As Doors Close'** – In this mode the 3D detection is activated as the doors begin to close. The system will allow up to three consecutive 3D triggers, after which the 3D detection is turned off leaving only the light curtain detection. If the light curtain is broken then 3D detection is enabled again. This mode is recommended for door openings exceeding 1200mm.
- **'At 800mm'** – In this mode the 3D detection is activated as the doors are closing and have reached a separation of 800mm (32"). This mode can be used on wider doors to restrict the range of 3D detection into the landing. As previously the system will allow up to 3 consecutive 3D triggers, after which the 3D

detection is turned off leaving only the light curtain detection. If the light curtain is broken then 3D detection is enabled again.

- **'At 800mm'** – In this mode the 3D detection is activated as the doors are closing and have reached a separation of 800mm (32"). This mode can be used on wider doors to restrict the range of 3D detection into the landing. As previously the system will allow up to 3 consecutive 3D triggers, after which the 3D detection is turned off leaving only the light curtain detection. If the light curtain is broken then 3D detection is enabled again.

Operation

The Pana40 Plus-3D system consists of a Transmitter Detector (TX), a Receiver Detector (RX) and a Controller.

The light curtain is achieved by infra-red light beams travelling directly between TX and RX detectors. The TX has 40 transmit diodes, while the RX has 40 receive diodes. The system generates 40 beams with a Pana40 Plus Controller or 194 beams with a Pana194 Plus Controller. Interrupting any beam triggers the doors to re-open.

The 3D detection is achieved by infra-red light beams reflecting from objects in the 3D zone. These beams operate upwards or downwards or straight out from the detectors at an angle of approximately 45° to the plane of the doors. The TX has 15 transmit diodes while the RX has 19 receive diodes.

Note - the detectors must always be mounted with the TX on the left and the RX on the right so that the 3D detection looks out to the landing and not in towards the lift car (see Fig 1).

The 3D detection range is approximately half the door separation (e.g. at a separation of 800mm the 3D range is approximately 400mm from the light curtain.). So as the doors close the 3D zone moves inwards and concentrates close to the landing doors.

The system knows the door separation by measuring the direct beam intensity. To ensure reliable operation it automatically disables 3D detection when separation is less than 250mm. The installer can configure the system to close in certain circumstances to prevent the doors being held open indefinitely by someone standing near the doors(see the 3D Configuration section for details). The light curtain remains active

3D Operating Mode	Switch 1	Switch 2
'As Doors Close'	down	down
'At 800mm'	down	up
'3D Timeout – 20 seconds'	up	down
'3D Timeout – 10 seconds'	up	up

Table 1 - 3D Operating Mode

3D Sensitivity	Switch 3	Switch 4
Highest	up	up
Intermediate	down	up
Lowest	up	down
3D detection off	down	down

Table 2 - 3D Sensitivity

regardless of whether the 3D detection is active or not.

Installation Notes

When installing a Pana40 Plus-3D system the following precautions must be observed for trouble free operation:-

- The landing doors must not lead the car doors by more than the suggested permissible amount as shown in Fig 7. **Note:** The maximum permissible landing door lead is further reduced if the detectors are set back from the leading edge of the car doors.
- Always mount the detectors as close to the door edge as possible.
- Sightguards should not be used with Pana40 Plus-3D detectors.
- For openings exceeding 1200mm it is recommended that 'As Doors Close' mode is used.
- The detectors must be set no more than 10mm apart when the doors are fully closed. The detectors must be aligned to within ±5mm of the detector centre-line for Ultrastim detectors and within ±8mm for all other detectors.

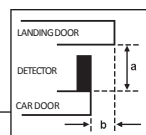
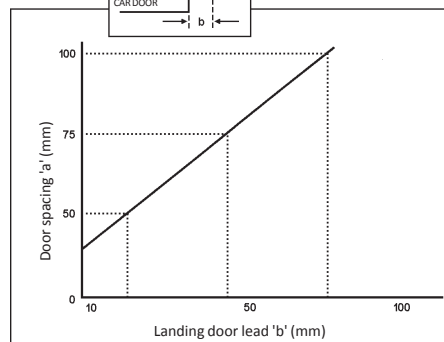

Fig 7: 3D detector position



Note: this graph is indicative only and relies on the accuracy of installation and the reflective properties of the landing doors and the lift entrance

Fig 8: Maximum permissible landing door lead 'b' versus door spacing distance 'a'

SPECIFICATIONS

Pana40 Plus-3D Detectors Model 770

Size	43.5 (1 ¹¹ / ₁₆ ") x 62.5 (2 ¹ / ₂ ") x 2100mm (6ft 10 ¹¹ / ₁₆ ") standard version 40.0 (1 ⁹ / ₁₆ ") x 17.3 (1 ¹ / ₁₆ ") x 2100mm (6ft 10 ¹¹ / ₁₆ ") leading edge version	
Cable Length	725mm + 4m extension	
Distance between bottom beam & bottom of housing	20mm for light curtain	
Distance between top beam & bottom of housing	1800mm for light curtain	
Range - 2D Range - 3D	6.0m max typically half door separation, to max of 1.2m	
Number of diodes per detector	55 TX Detector 59 RX Detector	
Number of beams between detectors	40 or 194 depending on Controller	
Packed Weight	5.6kg	
Maximum Voltage in Detectors	5.6V DC	
Alignment Requirements	10mm max separation and aligned within ±8mm of the detector's centre lines (when doors are fully closed)	
Maximum power consumption	0.3W	
Fixing Kit	for 770 000 for 770 010 for 770 020	2 kits, each including 5 plastic brackets, 1 end plate, 1 earthing screen, 25 self-tapping screws, 5 P-Clips, 1 drilling template, 1 grommet, 1 earthing bracket, 5 spring washers. 2 kits, each including 4 fixing bolts/nuts/washers, 5 P-Clips, 15 self-tapping screws. 2 kits, one consisting of 5 plastic brackets, 1 end plate, 1 earthing screen, 25 self-tapping screws, 5 P-Clips, 1 drilling template, 1 grommet, 1 earthing bracket, 5 spring washers, the other consisting of 4 fixing bolts/nuts/washers, 5 P-Clips, 15 self-tapping screws

Pana40 Plus-3D Detectors Model 771

Size	15.5 (5/ ₈ ") x 33.5 (1 ⁶ / ₁₆ ") x 2000mm (6ft 6 ³ / ₄ ")	
Cable Length	665mm + 4m extension	
Distance between bottom beam & bottom of housing	17mm for light curtain	
Distance between top beam & bottom of housing	1800mm for light curtain	
Range - 2D Range - 3D	6.0m max typically half door separation, to max of 1.2m	
Number of diodes per detector	55 TX Detector 59 RX Detector	
Number of beams between detectors	40 or 194 depending on Controller	
Packed Weight	3.3g	
Maximum Voltage in Detectors	5.6V DC	
Alignment Requirements	10mm max separation and aligned within ±8mm of the detector's centre lines (when doors are fully closed)	
Maximum power consumption	0.3W	
Fixing Kit	10 P-Clips, 10 No.8x12 self-tapping screws, 10 No.8x32 self-tapping screws	

Pana40 Plus-3D Detectors Model 774

Size	9.8 (3/ ₈ ") x 37.3 (1 ¹⁵ / ₃₂ ") x 2000mm (6' 6 ³ / ₄ ")	
Cable Length	725mm plus 4m extension	
Distance between bottom beam & bottom of housing	26mm for light curtain	
Distance between top beam & bottom of housing	1808mm for light curtain	
Range - 2D Range - 3D	5.0m max typically half door separation, to max of 1.2m	
Number of diodes per detector	55 TX Detector 59 RX Detector	
Number of beams between detectors	40 or 194 depending on Controller	
Packed Weight	2.7kg (3.4kg Export)	
Maximum Voltage in Detectors	5.6V DC	
Alignment Requirements	10mm max separation and aligned within ±8mm of the detector's centre lines (when doors are fully closed)	
Maximum power consumption	0.3W	
Fixing Kit	10 P-Clips, 10 No.6x20 self-tapping screws, 10 No.6x16 self-tapping screws, 12 No 8 self-tapping screws, 10 M3.5 shakeproof washers, 2 M4 shakeproof washers	

Sleep Software Patent Nos	UK	9822359.7	3D Patent Nos	Europe	EP0699 619
	Germany	29918009.3		USA	5,698,824
	Japan	291527/1999		Japan	3088936
	USA	09/416,585			

Pana40 Plus-3D Model 840/841/843	
Size	202mm(8") x 186mm(7 ⁵ / ₁₆ ") x 52mm (2 ¹ / ₁₆ ")
Weight	1150g
Packed Weight including Cables	1750g
Extension Cable (2 per set)	Length 4m (13ft 1 ¹ / ₂ ")
Voltage Requirements	All versions will also operate from 11-25VDC 3D Model 841 comes with voltage selection switch
Power Consumption	5VA maximum with detectors fitted
Door Operator Relay	240V AC, 10A (2nd programmable relay provided in Model 843)
Case Material	Steel-sprayed satin black
Indicators	13mm (½") single character 8 segment LED display showing controller status or fault code depending on Mode switch position
Mode	Switched NORMAL/TEST
Trigger Duration	250ms typical
Time-Out	Switchable ON/OFF, 10-70s adjustable by control
Beeper	Switched ON/OFF
Pana40 Plus-3D typical scan time	65ms (40 beams) at 800mm separation
Pana194 Plus-3D typical scan time	250ms (194 beams) at 800mm separation
Operating Temperature Range	-10°C to 65°C as per BS2011 Pt.2.1 Ab and BS2011 Pt.2.2 Bb
Operating Temperature/Humidity Cycle	+55°C 6x24hr cycles as per BS2011 Pt 2 Db:1981 variant 2
Vibration	20-500Hz 1.0g rms 4hrs 3 axis as per BS2011 Pt.2.1 Fd
EMC compliance to	Emissions to EN50081 Part 1. Immunity to EN50082 Part 2

Ordering Information

When ordering a system note that one set of detectors and one controller are needed.

Part Nos. Description		
Detectors	770 000	Set of 2 Standard Pana40 Plus-3D Detectors with fixing kits
	770 010	Set of 2 Leading Edge Pana40 Plus-3D Detectors with fixing kits
	770 020	Set of Mixed Pana40 Plus-3D Detectors with fixing kit (consisting of 1 Leading Edge and 1 Standard detector)
	771 000	Set of 2 Slimline Pana40 Plus-3D Detectors with fixing kit
	774 000	Set of 2 Ultraslim Pana40 Plus-3D Detectors with fixing kits
Controllers	840 022	Model 840 Pana40 Plus-3D Controller - 240V AC, DC, 40 beams
	840 023	Model 840 Pana40 Plus-3D Controller - 110V AC, DC, 40 beams
	840 024	Model 840 Pana194 Plus-3D Controller - 240V AC, DC, 194 beams
	840 025	Model 840 Pana194 Plus-3D Controller - 110V AC, DC, 194 beams
	841 008	Model 841 Pana40 Plus-3D Controller - 240/110V AC, DC, 40 beams
	841 009	Model 841 Pana194 Plus-3D Controller - 240/110V AC, DC, 194 beams
	843 022	Model 843 Pana40 Plus-3D Controller - 240V AC, DC, 40 beams
	843 023	Model 843 Pana40 Plus-3D Controller - 110V AC, DC, 40 beams
Spares and Accessories		
Finger Guards	007 137	PVC Finger Guard for RX Slimline Detector – right hand side
	007 138	PVC Finger Guard for TX Slimline Detector – left hand side
Extension Cable	015 199	4m travelling cable for TX or RX Pana40 Plus-3D Detector

This product is designed for use in elevators with powered automatic doors where the closing force is 25N/mm or less as per EN81 requirements. It should be installed by qualified personnel only, therefore any use outside of this application is at the installer's own risk and should be assessed appropriately.

As a result of our policy of continual improvement, the information in this document is subject to change without notice and it is intended only as general guidance on product performance and suitability. This information shall not form part of any contract.