

Memco Panachrome3D



PRODUCT INFORMATION SHEET

Panachrome 3D is the revolutionary new lift safety detection system offering maximum passenger protection. The traditional infra-red light curtain is coupled with 3D detection in the landing zone and coloured indicators that operate on door movement. The detectors will illuminate green if the doors are opening, flash red as they start to close, and stay red as the doors move together.

The combined system is an effective solution for sites where additional safety is required by users, for example; rest homes, hospitals and public access buildings.

- ✓ Complies with EN81-70 legislation - Disability Discrimination Act
- ✓ Coverage exceeds minimum requirements of 25mm to 1800mm
- ✓ Coloured red/green indicators to highlight door movement
- ✓ Dense infra-red 154 beam light curtain
- ✓ 4m pluggable cable
- ✓ 6m 2D range
- ✓ Can be used on centre-opening and side-opening doors
- ✓ Patented product

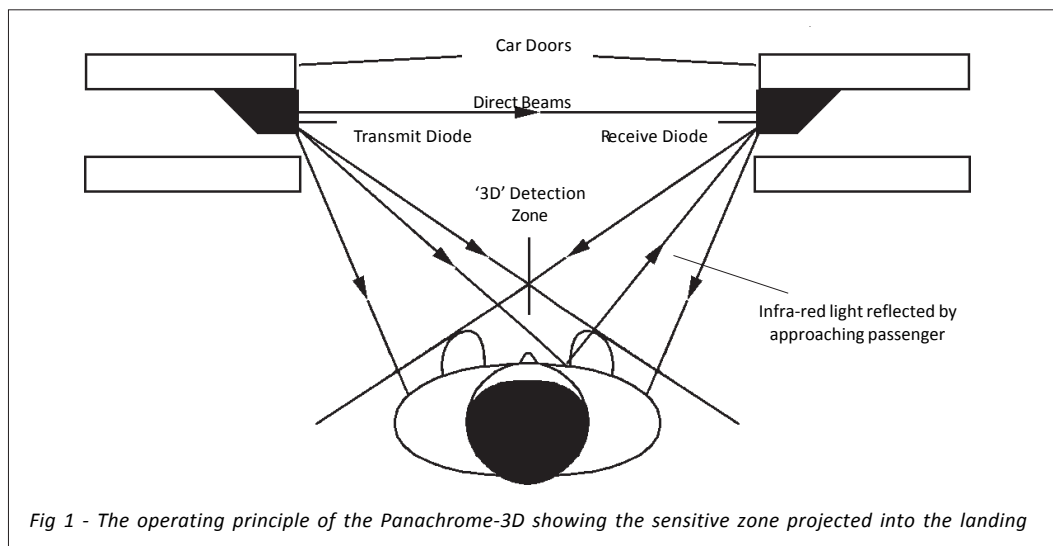

Fig 1 - The operating principle of the Panachrome-3D showing the sensitive zone projected into the landing

1. VISUAL INDICATORS

The coloured indicators are evenly spread throughout the detector edge to display green on opening, and flash red when the doors are starting to close. This changes to solid red as the doors move together, and the lights are switched off after door closure.

The visual indicators can be switched off on one side if required, to accommodate a side-opening door.

2. INFRA-RED CURTAIN

A curtain of 154 beams operates between the car doors to prevent passengers becoming trapped between the closing doors. The light curtain beams operate from 18mm to 1831mm (43mm) & 17mm to 1833mm (10mm) as measured from the base of the detector, to meet EN81-70.

3. 3D DETECTION ZONE

The 3D Detection Zone covers from just above floor level to 1650mm. The 3D detection range is equal to approximately half the door separation. As the doors close the 3D detection zone moves inwards. The system can be configured for different operating modes to suit particular installation needs. For example the "3D Timeout" mode is ideal for hospitals because the doors will only start to close if the 3D detection zone is clear.

The Panachrome 3D detectors suit a wide variety of doors including both centre-opening and side-opening doors. The 3D Panachrome controller (C3850) is available for 18-25V DC and a universal AC supply of 85 to 240V.

DETECTOR FEATURES

- ✓ Panachrome 3D detectors are designed for dynamic fixing only
- ✓ Can be used on side-opening and centre-opening doors
- ✓ Visual indicators can be turned off on either detector
- ✓ Rigid PVC extrusions for easy installation on side & centre-opening
- ✓ Separate, pluggable cable tested at >50 million cycles
- ✓ Self-drilling screws for fast, easy fixing

10mm Profile

The detectors are 10mm wide which allows them to be fitted to virtually all lifts. They are simply mounted using countersunk headed self-tapping screws, (Fig 2), or with a fixing clamp plate, (Fig 3). This is used where there is insufficient reach for standard fixing method.

43mm profile

For installations with a wider sill arrangement, the 43mm wide Panachrome is ideal. Fixings for two door types are included as standard. Centre-opening using 2 "L" brackets (Fig 4) or side-opening using an "L" bracket and a slampost bracket (Fig 5). The detectors are then fixed to the doors using self-drilling screws.

CONTROLLER FEATURES

The Panachrome 3D Controller operates the Panachrome 3D detectors. It is housed in a black steel box which is extremely durable and normally fitted on top of the lift car using self-tapping screws.

Visual Indicator Switching:

There are 2 different ways to switch the red indicator on closure and green indicator on opening.

- 1) **Automatic software switching:** In this mode, the software integrated in the Panachrome controller can detect the door movement and changes the light colour. This solution requires no extra connections. When a nudging system is used to force the doors to close and to maintain the red display, connect the nudging signal to the CLOSING input.
- 2) **External signals:** In this mode, two signals (doors opening and doors closing) from the lift controller or door operator change the light colour. This solution gives an optimum result especially on high-speed doors. Any available voltage 12V-230V AC or DC can be used.

Adjustments:

The following adjustments can be easily made, on site, to adapt the operation of the Panachrome light to different lift configurations.

- 1) Visible indicator switching mode for auto-switching or external signals.
- 2) Permanent visible light disabling on either antenna.

Second Relay Functions:

A second relay can be configured by means of a 6-way DIP switch to operate on a 3D trigger, special timeout or fault condition. Refer to the installation sheet for full details.

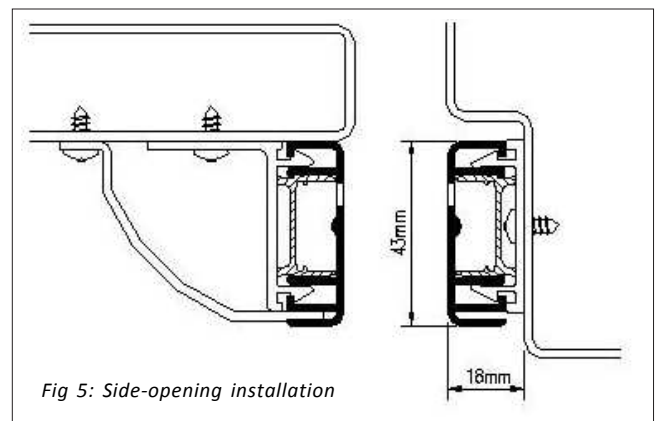
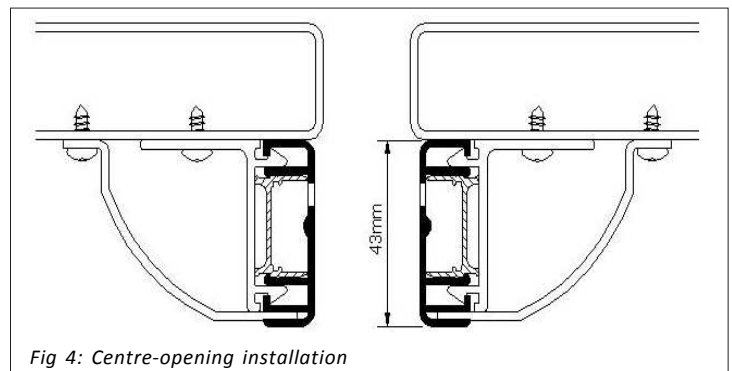
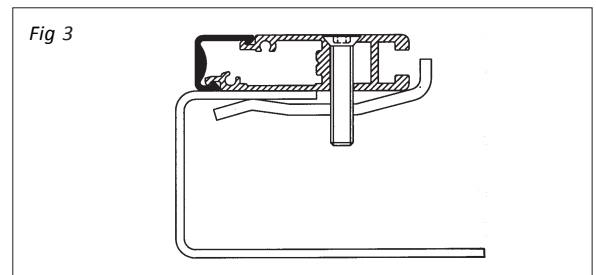
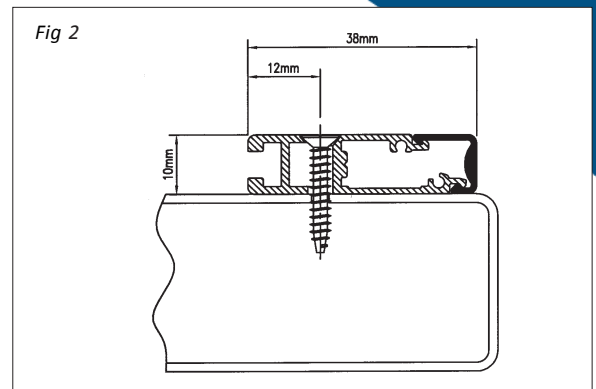

2D LIGHT CURTAIN FEATURES (see Fig 6)

▪ Power Reduction Software

This patented software feature is designed to put the system into a less active state when the lift is not in use and prolong the life span of the detectors. When the detectors stop very close to each other, the Power Reduction mode is operated after a delay of 2 minutes. In this mode the scan speed is reduced to once every ½ second. If the doors start to open, or an obstruction is detected, then the normal scanning and trigger mode is resumed.

▪ Audible Tone

A tone can inform users they are preventing the doors from closing.

▪ Test Diagnostics

Special test diagnostics allows the installer to quickly check for system faults. Simply turn the 'Mode' switch to 'Test' and the system will report any faults on a diagnostics display, e.g., 'cable disconnected'.

▪ Light Curtain Timeout

Setting the 'Timeout' switch on will allow a partially damaged detector to continue working safely until it can be replaced. It does this by ignoring a permanent trigger on up to 5 non-adjacent beams (e.g. due to vandalism). The timeout period is adjustable from 10 seconds to 70 seconds.

3D DETECTION FEATURES

▪ 3D Configuration Switches

The controller is fitted with a 4-way DIP switch. Switches 1 and 2 set the 3D Operating Mode while switches 3 and 4 set the 3D sensitivity.

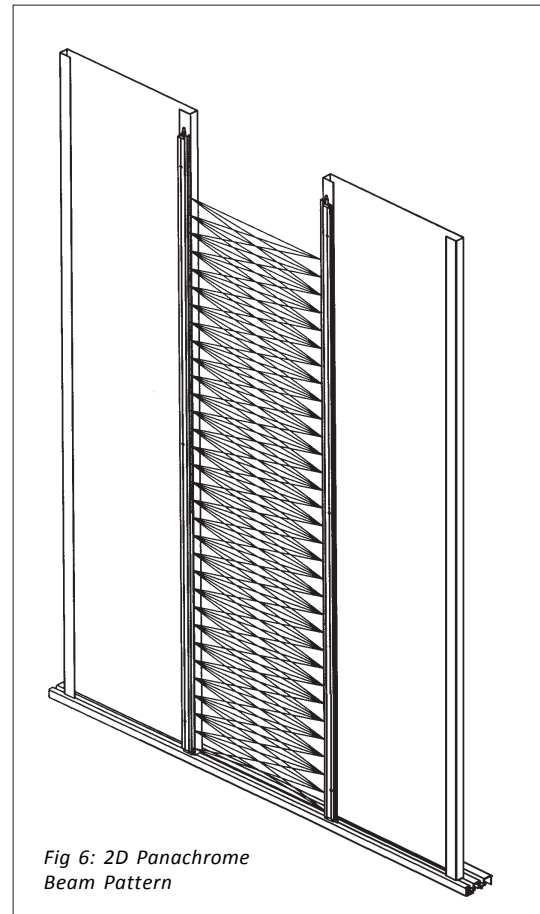

Fig 6: 2D Panachrome Beam Pattern

3D Operating Mode	Switch 4/1	Switch 4/2
3D Active 'As Doors Close'	OFF	OFF
3D Active 'At 800mm'	OFF	ON
'3D Timeout – 20 secs'	ON	OFF
'3D Timeout – 10 secs'	ON	ON

Table 1 - 3D Operating Mode

3D Sensitivity	Switch 4/3	Switch 4/4
Highest	ON	ON
Intermediate	OFF	ON
Normal	ON	OFF
3D detection off	OFF	OFF

Table 2 - 3D Sensitivity

▪ '3D Timeout - 20 seconds'

In this mode the 3D detection is activated when the doors have reached their fully opened position. The system will allow a continuous 3D trigger to hold the door open for 20 seconds. If the 20 second timer expires then the doors are allowed to close with a warning beep. (This beep will occur regardless of the 'Tone' switch position). If the 3D zone becomes clear before the 20 second timer expires then the timer is reset and the doors are allowed to close. If the light curtain is broken then the timer is reset and the doors re-opened.

▪ '3D Timeout - 10 seconds'

This mode is identical to '3D Timeout - 20 seconds' except that the 3D timeout period is now fixed at 10 seconds.

- **'As Doors Close'**

In this mode the 3D detection is activated as the doors begin to close. The system will allow up to 3 consecutive 3D triggers, after which the 3D detection is turned off leaving only the light curtain detection. If the light curtain is broken then 3D detection is enabled again. This mode is recommended for door openings exceeding 1200mm.

- **'At 800mm'**

In this mode the 3D detection is activated as the doors are closing and have reached a separation of 800mm (32"). This mode can be used on wider doors to restrict the range of 3D detection into the landing. As previously, the system will allow up to 3 consecutive 3D triggers, after which the 3D detection is turned off leaving only the light curtain detection. If the light curtain is broken then 3D detection is enabled again.

OPERATION

The Panachrome-3D system consists of a Transmitter Detector (TX), a Receiver Detector (RX) and a Controller.

Light Curtain

The light curtain is achieved by infra-red light beams travelling directly between TX and RX detectors. The TX has 32 transmit diodes, while the RX has 32 receive diodes. The system generates 154 beams; interrupting any beam triggers the doors to re-open.

3D

The 3D detection is achieved by infra-red light beams reflecting from objects in the 3D zone. These beams operate upwards downwards or straight out from the detectors at an angle of approximately 45° to the plane of the doors. The TX has 16 transmit diodes while the RX has 15 receive diodes.

The detectors must always be mounted with the TX on the left and the RX on the right so that the 3D detection looks out to the landing and not in towards the lift car (see Fig 1 on front page).

The 3D detection range is approximately half the door separation, e.g. at a separation of 800mm the 3D range is approximately 400mm from the light curtain. As the doors close the 3D zone moves inwards and concentrates close to the landing doors.

The system calculates the door separation by measuring the direct beam intensity. To ensure reliable operation it automatically disables 3D detection when separation is less than 300mm. The installer can configure the system to close in certain circumstances to prevent the doors being held open indefinitely by someone standing near the doors (see the 3D Configuration section for details). The light curtain remains active regardless of whether the 3D detection is active or not.

INSTALLATION NOTES

When installing a Panachrome 3D system, the following precautions must be observed for trouble-free operation:

- The landing doors must not lead the car doors by more than the suggested permissible amount as shown in Installation Sheet C3540 850 and C3510 850.
- Always mount the detectors as close to the door edge as possible.
- Sightguards cannot be used with Panachrome 3D detectors.
- For an opening exceeding 1200mm, it is recommended that 'As Doors Close' mode is used.
- The detectors must be set no more than 10mm apart when the doors are fully closed.
- The detectors must be aligned to within ±5mm of the detector centreline.

TECHNICAL SPECIFICATIONS					
Size	C3540		C3510		
Panachrome Detectors	43mm x 18mm x 2100mm		10mm x 38mm x 2000mm		
Panachrome C3850 Controller	250mm x 206mm x 59mm		250mm x 206mm x 59mm		
Ext. Cables 015 455 (2 cables req'd per set)	4m		4m		
Packed Weights					
Panachrome 3D Detectors	6.2kg		3.4kg		
Panachrome 3D Controller C3850 inc. Extension Cables (2 per set)	2.52kg		2.52kg		
Detector Specifications					
Distance between bottom beam and bottom of housing	18mm		17mm		
Distance between top beam and bottom of housing	1831mm		1833mm		
Range - 3D	Typically half door separation, to max of 1.2m				
Maximum voltage in detector	18V DC		18V DC		
Maximum power consumption TX or RX	1.7W each when visual indication turned on				
Operating temperature range	-10°C to +65°C as per BS201 1 Pt.2.1 Ab and BS2011 Pt.2.2 Bb				
EMC compliance to	Emissions to EN 12015:1998; Immunity to EN12016:2004				
Ingress Rating	IP55		IP65		
Light Immunity Rating	60,000 lux		60,000 lux		
CSA Certification Details	1586962 (LR 53335), Master Contract: 173023, Date Issued: 2005/01/14				
Patents	Singapore USA Denmark	200506875 US7,771,080 B2 DK/EP 1626924	Turkey Europe Australia	B66B 13/26, E05F 15/00 EP1626924 0309310.1	
Sleep Software Patent Nos	UK Germany Japan USA	9822359.7 29918009.3 291527/1999 09/416,585	Patent Nos	Europe USA Japan Canada Singapore	EP06966 619 5,698,824 3088936 2,153,514 116374
Controller Specifications					
Voltage requirements	Universal AC supply 85 - 240V AC or 18 to 25V DC				
Power consumption	5VA maximum with detectors fitted, visual indication on				
Door operator relay	250V AC, 24V DC at 5A				
Case Material	Epoxy Painted Mild Steel				
Trigger Duration	250mS typical 2D, 1sec typical 3D				
Timeout	Switched ON/OFF 10-70 seconds adjustable				
Visual Indication trigger input	12V to 230V, AC or DC. Jumper selectable for rising or falling edge voltage range of signal				

Part Nos	Ordering Information	Profile
C3510 000	Set of TX, RX Detectors and Fixing Kit	10mm
C3510 001	Transmitter Detector (TX)	10mm
C3510 002	Receiver Detector (RX)	10mm
C2510 803	Clamp Kit to fit one Detector	10mm
C3540 000	Set of TX, RX Detectors and Fixing Kit	43mm
C3540 001	Transmitter Detector (TX)	43mm
C3540 002	Receiver Detector (RX)	43mm
C3540 801	Fixing Kit	43mm
C3850 000	Universal 85-240V AC Panachrome Controller	

This product is designed for use in elevators with powered automatic doors where the closing force is 25N/mm or less as per EN81 requirements. It should be installed by qualified personnel only, therefore any use outside of this application is at the installer's own risk and should be assessed appropriately.

As a result of our policy of continual improvement, the information in this document is subject to change without notice and it is intended only as general guidance on product performance and suitability. This information shall not form part of any contract.

A HALMA COMPANY

