



PRODUCT
INFORMATION
SHEET

MEMCOM

www.memcom.eu

EMERGENCY ALARM DEVICE

- **Easy Programming** – using keypad and microphone, phone, GSM or PC.
- **Allows full compliance with EN81-28 and EN81-70.**
- **Connect up to 8 Memcom units to the same phone line.**
- **Reassurance/Guidance/Location Message** – up to 3 separate voice messages can be programmed.
- **Program Options** – up to 4 alarm numbers and 2 technical alarms.
- **Backlit LCD display for programming and status information.**
- **EN81-28 test call compliance via Memco Globalnet or Memcom ETR software.**
- **Memcom ETR Software** – for easy management of emergency, technical and EN81-28 auto-test calls.
- **Programmed number and technical alarm talk-back facility.**
- **Multi-Point Station for pit, machine room or cabin using 2 wires only.**
- **GSM module available.**
- **Stand-alone battery back-up of complete system including GSM.**
- **Inductive Loop and test meter available.**

The Memcom system has been designed to provide trapped passengers with easy, hands-free connection to emergency help. High quality advanced electronics give excellent sound, acoustics and reliability.

A trapped passenger simply presses the emergency button inside the lift and Memcom automatically connects to one of 4 pre-programmed telephone numbers. The lift location can be identified by the Memcom ETR software or via the programmed voice location message. The trapped passenger and call receiver can then speak with each other. Additional numbers are available for EN81-28 test calls, as well as technical alarm calls. Two models are available for easy installation to either the elevator car operating panel (COP) or elevator cabin roof (TOC).

The Memcom features a keypad, backlit LCD display and built-in microphone for easy programming. Wiring is minimised on the COP version with built-in yellow and green LEDs for use as pictograms to EN81-70 and EN81-28. The Multi-Point Station (MPS) accessory for use in the machine room, pit and top of cabin requires only a twisted pair of wires for connecting up to 3 MPS units. The powerful battery can support the entire system including a GSM module in the machine room, if required.



Fig 1

Installation Options

COP Car Opening Panel – Inside the Lift Car

Fix the Memcom COP to the back of the control panel inside the car; connect the telephone line, external call points, the relevant external buttons, pictograms and accessories. No external microphone or speaker is required; however, they may still be fitted if desired. Finally, connect 230v AC or 24v DC power and the installation is complete.

TOC – Top of the Lift Car

Fix the Memcom TOC to the roof of the lift car; connect the telephone line, external call points, the relevant external buttons, pictograms and accessories. Ensure that the external microphone is also connected. Finally, connect 230v AC or 24v DC power and the installation is complete, no cutting of the car or control panel is required.

The Memcom has a powerful speaker which can be clearly heard inside the lift. The auto-gain circuitry ensures correct microphone volume constantly, to ensure feedback-free operation.

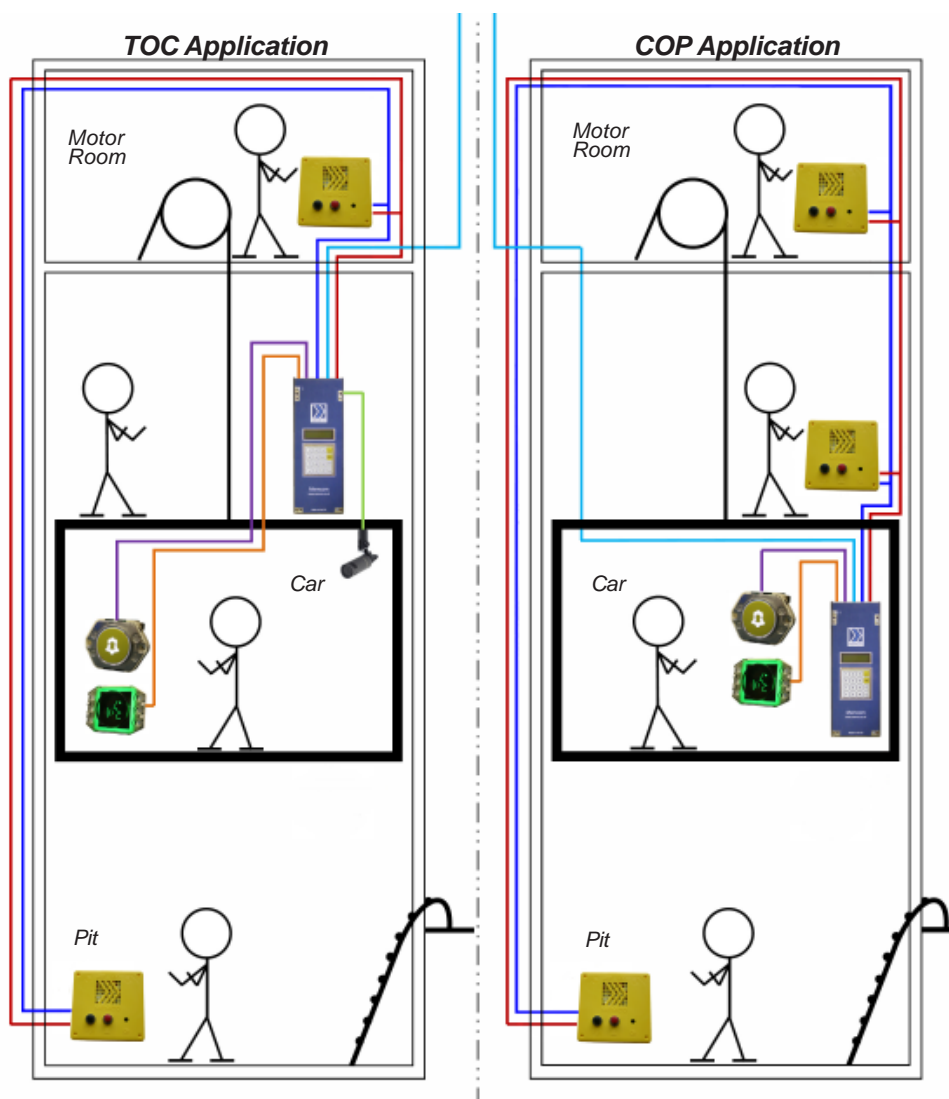

Note

- Images are for illustration purposes only, please refer to installation guide for more detail.
- All external call points are connected in parallel using two core cable.
- Up to three line powered communication points, additional call points require an external supply.

Memcom Connection Diagram

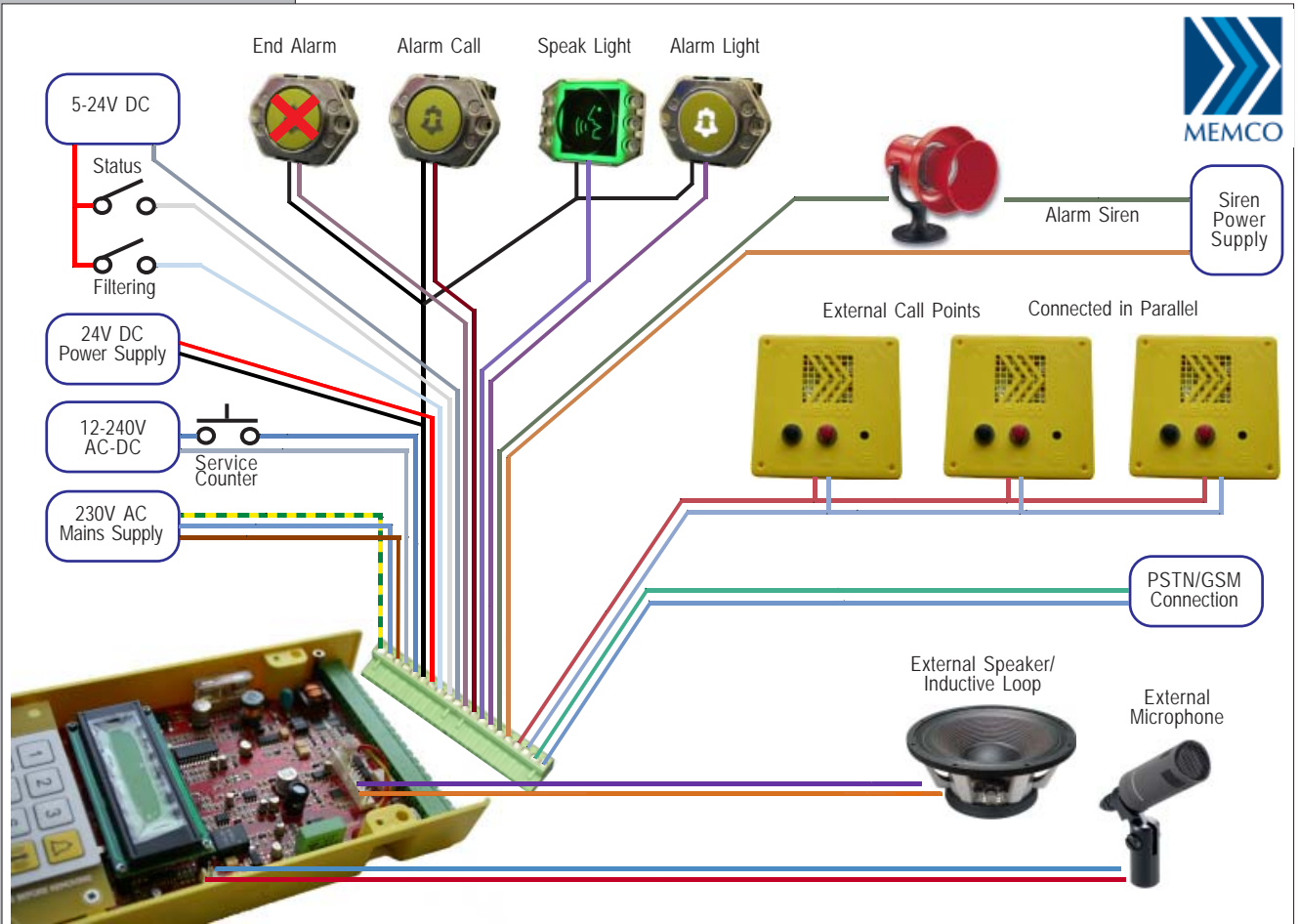

Accessories and Features

Multi-Point Station (MPS) - The Memcom MPS is an easy to fit solution to provide external emergency telephone points for the lift engineer. It allows local communication between up to 3 different points of the lift installation, a benefit during commissioning and installation.

Inductive Loop - The Memcom Inductive Loop connects to the JP6 accessories header inside the Memcom to provide audibility for the hard-of-hearing.

Pictograms - Yellow and green LEDs are visible in the base of the Memcom to allow compliance with EN81-70 when combined with COP engraving. There are alternative outputs available to drive independent pictograms.

Service Counter - Memcom has the ability to count elevator trips and then generate a technical alarm call from a pre-programmed trip limit value, for example, to prompt a service visit.

Lift Monitoring - As well as filtering calls using a doors open signal, there is a spare technical input for monitoring the lift status.

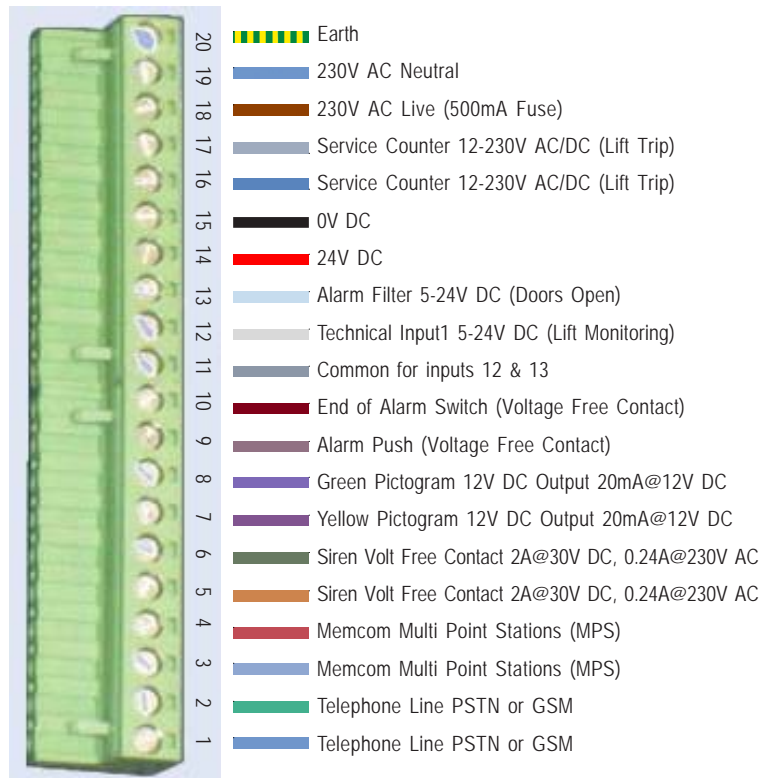

Programming

The Memcom can be easily programmed using any of the following methods:

1. Directly from the keypad using the built-in microphone, keypad and display
2. With a telephone handset via a fixed line.
3. Using a GSM or mobile telephone handset.
4. Configurable Memcom ETR software connected via a PC and modem.
5. Remotely by your local Memco Branch Office

Programming for Emergency Calls

The Memcom should be programmed to dial the lift rescue service in the event of a trapped passenger pushing the emergency button. The lift location can be identified by activating the lift location message when in Confirmation Mode (see table below) and after the message plays, 2-way communication is then active. Alternatively, using the Memcom ETR software (see Memcom ETR software datasheet) with a PC & handset, allows the specific Memcom unit to be identified and the unique unit record is immediately displayed. The person receiving the emergency call may also be able to locate the lift using CLI (Caller Line Identification) such as in a large call centre. The Memcom relies on DTMF tones for 2-way commands such as activating the location message.

Memcom Emergency Call Sequence

Sequence	Confirmation Mode	Sequence	Non-Confirmation Mode
1. Alarm Press	Yellow LED illuminates	Alarm Press	Yellow LED illuminates
2. Memcom dials Phone No.1	Reassurance Message "You are now being connected"		Reassurance Message "You are now being connected"
3. Phone Pick up	Instruction Message "Press # to speak to the trapped passenger or 3 for location" followed by 3 beeps	Memcom dials Phone No.1	
4. Press #	Green LED illuminates Two way speech	Phone Pick Up	Green LED illuminates Two way speech
5. Press 3	Green LED illuminates Play location message Two way speech		
6. At 2min 30secs On line reminder	Instruction Message "The call will be terminated in 30secs push # to continue"	At 2min 30secs On line reminder	Instruction Message "The call will be terminated in 30secs push # to continue"
7. End Call	Operator presses * # to end	End Call	Operator presses * # to end

Memcom Emergency Call Sequence – No Answer

Sequence	Confirmation Mode	Sequence	Non-Confirmation Mode
1. Alarm Press	Yellow LED illuminates	Alarm Press	Yellow LED illuminates
2. Memcom dials Phone No.1	Reassurance Message "You are now being connected...."	Memcom dials Phone No.1	Reassurance Message "You are now being connected...."
3. No Answer	After 30 secs, hangs up	No Answer	Rings for 30secs, hangs up
4. Memco dials Phone No.2	Reassurance Message "You are now being connected...."	End Call	
	Sequence as from Step 3 above or dials telephone No.3		

EN81-28 3 Day Test Calls & Technical Alarms

The EN81-28 2004 requires that a lift emergency telephone device is checked every 3 days or less by simulating an emergency call (automatic test), and that any battery supporting the system has a minimum of 1 hour of life. The Memcom can be programmed to carry out the automatic test call & battery check to a PC using Memcom ETR software as required (see Memcom ETR software datasheet).

Alternatively, the installer has the option to program the Memcom to interface with the Memco Globalnet Internet Domain service for technical alarms and automatic test calls. Globalnet allows lift companies across Europe to manage their test calls **free** for the first year over the internet (up to a limit of 122 calls), and automatically generates and sends email notifications for units which do not test correctly. (see Memco Globalnet datasheet)

Globalnet Schematic

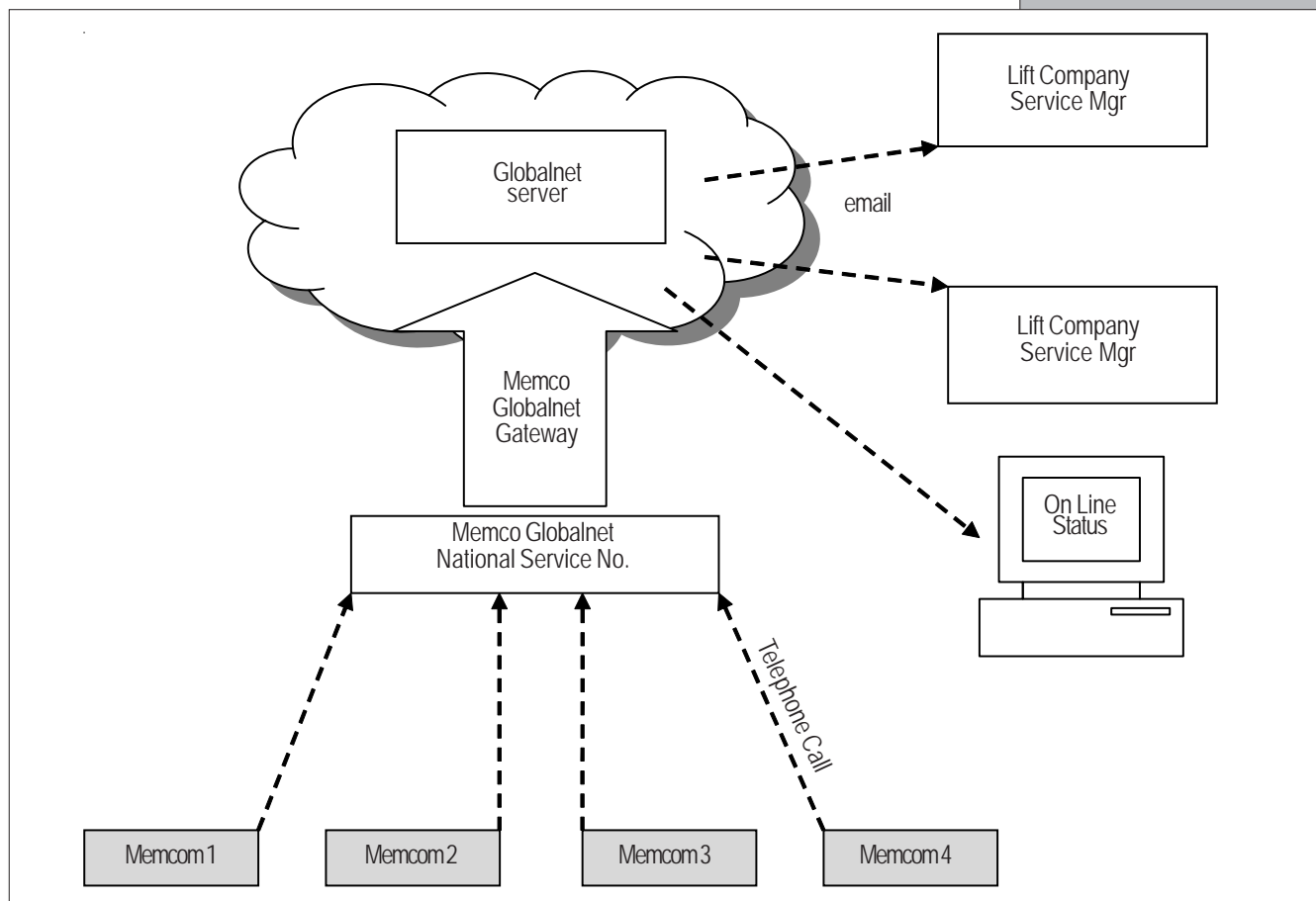

Technical Specifications	
Memcom 24V DC COP Version	Part no: 450 000
Memcom 24V DC TOC	Part no: 450 010
Memcom 24V DC or 85-230v AC TOC	Part no: 450 011
Multi Point Station (MPS)	Part no: 492 020
Memcom microphone	Part no: 070 070
Memcom battery	Part no: 001 963
Inductive Loop	Part no: 451 000
Dimensions:	300mm (L) x 112mm (W) x 30mm (H)
Operating Temperature:	0° to +50°C
Storage Temperature:	-10° to +50°C
Humidity:	0% to 80%
Vibration:	BS EN 60068-2-64:1995 and BS EN 60068-2-6:1996
Weight:	0.9kg (including battery)
I/O Connections:	<ul style="list-style-type: none"> 1 x telephone line 1 x inductive loop output 1 x multi-point station (MPS) 1 x emergency push-button input 1 x end of alarm push-button input 1 x speak pictogram 1 x alarm indication pictogram 1 x service counter 2 x technical inputs 1 x bell relay output 1 x microphone input 1 x external loudspeaker output
Supply Voltage:	90 – 230V AC, 50Hz. +10% -15% 24V DC +/- 6V
Internal Battery (supplied):	12V, 0.8Ah, sealed lead acid
	3 Unique Speech Messages, each up to 10 seconds long:- Message 1 = Lift Location Message 2 = Passenger Reassurance Message 3 = Guidance
Compliance	Regulatory Telephone Network (TBR-21)

A HALMA COMPANY



MEMCO LTD, CLYDE HOUSE
 REFORM ROAD, MAIDENHEAD
 BERKS SL6 8BY, UK
 TEL: +44 1628 770734
 FAX: +44 1628 621947
 www.memco.co.uk